

Model

AMML

Monitore autoscillante a leva

Self-oscillating lever operated monitor

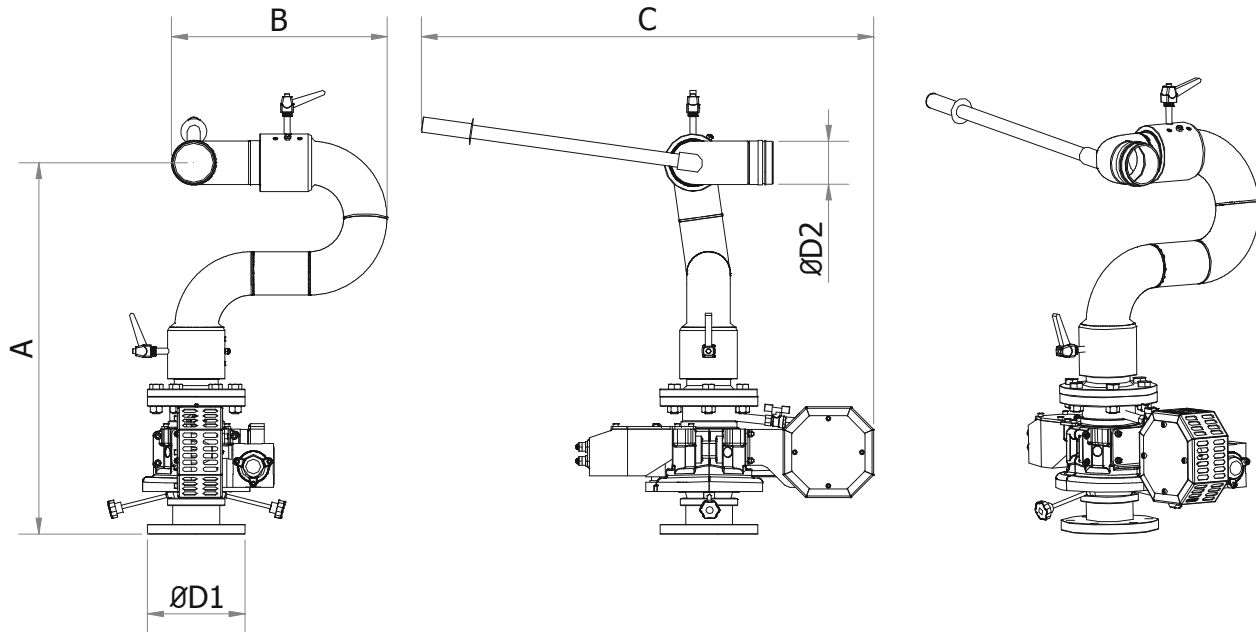

Modello Model	Corpo Body size	Portata max* max flow rate* l/min	ØD1 ISO PN16 ANSI #150	ØD2 GAS-BSP M	A	B	C	Peso Weight kg
AMML-65	2½"	2000	2½", 3", 4"	2½"	682	320	890	43
AMML-80	3"	4000	3", 4", 6"	3"	742	375	890	49
AMML-100	4"	7000	4", 6", 8"	4"	882	460	1038	59

* raccomandato / recommended

Specifiche – Specifications

Pressione di progetto: 16 bar	Design pressure: 16 bar
Pressione di lavoro massima (consigliata): 12 bar	Max. working pressure (advised): 12 bar
Rotazione: automatica/manuale indipendente	Rotation: independent manual/automatic
Corpo: acciaio inox AISI 304	Body: stainless steel AISI 304
Giunti in acciaio inox AISI 304 montati su sfere in bronzo fosforoso e muniti di ingrassatori	Joints in stainless steel AISI 304 mounted on phosphor bronze balls and supplied with grease nipples
Flangia di base: acciaio al carbonio	Inlet flange: carbon steel
Finitura: ciclo di verniciatura CSI#2 (vedi sezione 0-3-3-2)	Finish: coating cycle CSI#2 (see section 0-3-3-2)
Perdita di carico: vedi il sezione 4-1-15	Pressure loss: see section 4-1-15

A richiesta – Optional

Flangia: acciaio inox AISI 304 o 316	Inlet flange: stainless steel AISI 304 or 316
Corpo: acciaio inox AISI 316	Body: stainless steel AISI 316

Certificazioni - Certifications



C.S.I. s.r.l.

Rev. 15.0